

Model: Kaiser1	Date: 16-Mar-00	No.: MH306001a
----------------	-----------------	----------------

MB Correction

The items in bold have been corrected or added.

Modified Article: Parts Catalog Corrections		Prepared by: M. Mano	
From: Technical Service Dept., GTS Division			
Reason for Modification:	<input checked="" type="checkbox"/> Parts catalog correction	<input type="checkbox"/> Vendor change	<input type="checkbox"/> To meet standards ()
	<input type="checkbox"/> To facilitate assembly	<input type="checkbox"/> To improve reliability	
	<input type="checkbox"/> Part standardization	<input type="checkbox"/> Other	

The following part numbers were printed incorrectly in the parts catalog.

Mainframe (H306)

Incorrect part number	Correct part number	Description	Q'ty	Int	Page	Index	Note
G0291906	H3062714	Shutter - LDUNI	1		23	2	
H3062165	H3062178	Pressure Spring	2		33	5	
H3062183	H3062158	Pressure Roller Lever	2		33	6	
H3062181	H3062194	Rear Release Lever	1		33	9	
H3062180	H3062193	Front Release Lever	1		33	12	

SG3 unit (H133)

Incorrect part number	Correct part number	Description	Q'ty	Int	Page	Index	Note
H3066160	H3066162	PCB - SG3 - V34	1		3	2	

The above corrections will be included in the next release of the parts catalog.
(For the USA, this will be the first revised version)

Model: Kaiser1		Date: 26-Apr-00	No.: MH306002
Modified Article: Fusing Unit Part Number Information		Prepared by: M. Mano	
From: Technical Services Dept., GTS Division			
Reason for Modification:	<input type="checkbox"/> Parts catalog correction	<input type="checkbox"/> Vendor change	<input type="checkbox"/> To meet standards ()
	<input checked="" type="checkbox"/> To facilitate assembly	<input type="checkbox"/> To improve reliability	
	<input type="checkbox"/> Part standardization	<input type="checkbox"/> Other	

The following are the part numbers for the fusing unit assembly for the Kaiser 1.

Old part number	New part number	Description	Q'ty	Int	Page	Index	Note
-	H3062160	Fusing Unit	1				USA
-	H3062170	Fusing Unit	1				Eur./Asia

Model: Kaiser1		Date: 08-May-00	No.: MH306003
Modified Article: ADF Pickup Unit Part Number Information		Prepared by: M.Mano	
From: Technical Services Dept., GTS Division			
Reason for Modification:	<input type="checkbox"/> Parts catalog correction	<input type="checkbox"/> Vendor change	<input type="checkbox"/> To meet standards ()
	<input checked="" type="checkbox"/> To facilitate assembly	<input type="checkbox"/> To improve reliability	
	<input type="checkbox"/> Part standardization	<input type="checkbox"/> Other	

The following are the part numbers for the ADF Pickup Unit Assembly for the Kaiser1:

Old part number	New part number	Description	Q'ty	Int	Page	Index	Note
-	H3061207	ADF Pickup Unit	1				*1

*1: This part contains the following items (see the next page for each part number).

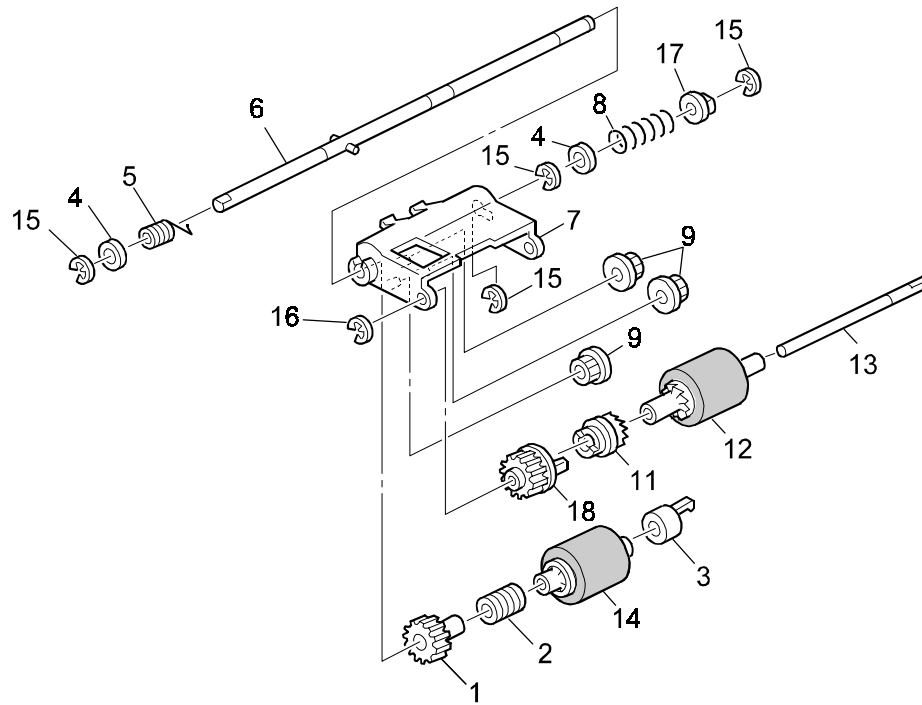

Model: Kaiser1	Date: 08-May-00	No.: MH306003
----------------	-----------------	---------------

H3061207 contains the following parts.

Index	Part number	Description	Q'ty	Note
1	H5211286	Gear -Feed Roller	1	
2	H5211316	Spring Clutch - M9	1	
3	H3061288	Clutch Roller	1	
4	H0062316	Spacer - Pickup Clutch	2	
5	H5211314	Spring Clutch - M6	1	
6	H3061370	Feed Shaft	1	
7	H3061274	Feed Bracket	1	
8	H3061320	Pressure Spring	1	
9	H3061361	Pickup Idler Gear	3	
10	H5211287	Gear - Pickup Roller	1	
11	H5211288	Collar - Pickup	1	
12	H3061302	Pickup Roller	1	
13	H3061276	Pickup Roller Shaft	1	
14	H3061301	Feed Roller	1	
15	07200040E	Retaining Ring - M4	4	
16	07200030E	Retaining Ring - M3	1	
17	08053480	Bushing - 6mm	1	

NOTE: The parts in bold are PM parts.

Model: Kaiser1		Date: 08-May-00	No.: MH306004
Modified Article: Parts Catalog Corrections		Prepared by: M.Mano	
From: Technical Services Dept., GTS Division			
Reason for Modification:	<input checked="" type="checkbox"/> Parts catalog correction	<input type="checkbox"/> Vendor change	<input type="checkbox"/> To meet standards ()
	<input type="checkbox"/> To facilitate assembly	<input type="checkbox"/> To improve reliability	
	<input type="checkbox"/> Part standardization	<input type="checkbox"/> Other	

Please make the following corrections to your parts catalogs.

For all models

Old part number	New part number	Description	Q'ty	Int	Page	Index	Note
	08053480	Bushing - 6mm	1		15	106	
H3063119	H3063139	Rear Support Plate	1	X/O	47	13	

For all models

Old part number	New part number	Description	Q'ty	Int	Page	Index	Note
H3063180	G0293950	Transfer Roller	1	O/O	27	24	

Schedule: After stock of the old part runs out.

For Europe/Asia, the new part has been used since the first mass production lot.

For all models

Old part number	New part number	Description	Q'ty	Int	Page	Index	Note
H3062158	H3062083	Pressure Roller Lever	1	X/O	33	6	

Schedule: Since February mass production for the USA.

For Europe/Asia, the new part has been used since the first mass production lot.

Model: Kaiser1	Date: 08-May-00	No.: MH306004
----------------	-----------------	---------------

For Europe/Asia *1

Old part number	New part number	Description	Q'ty	Int	Page	Index	Note
G0294161	H3065068	Thermofuse – 169°C	1	X/O	35	8	
-	G0294133	Cover Screw	2		35	35	*2

*1: These parts have been used since the first mass production lot.

*2: This part was not included in the original illustration (not a new part).

Please add the index description and illustration.

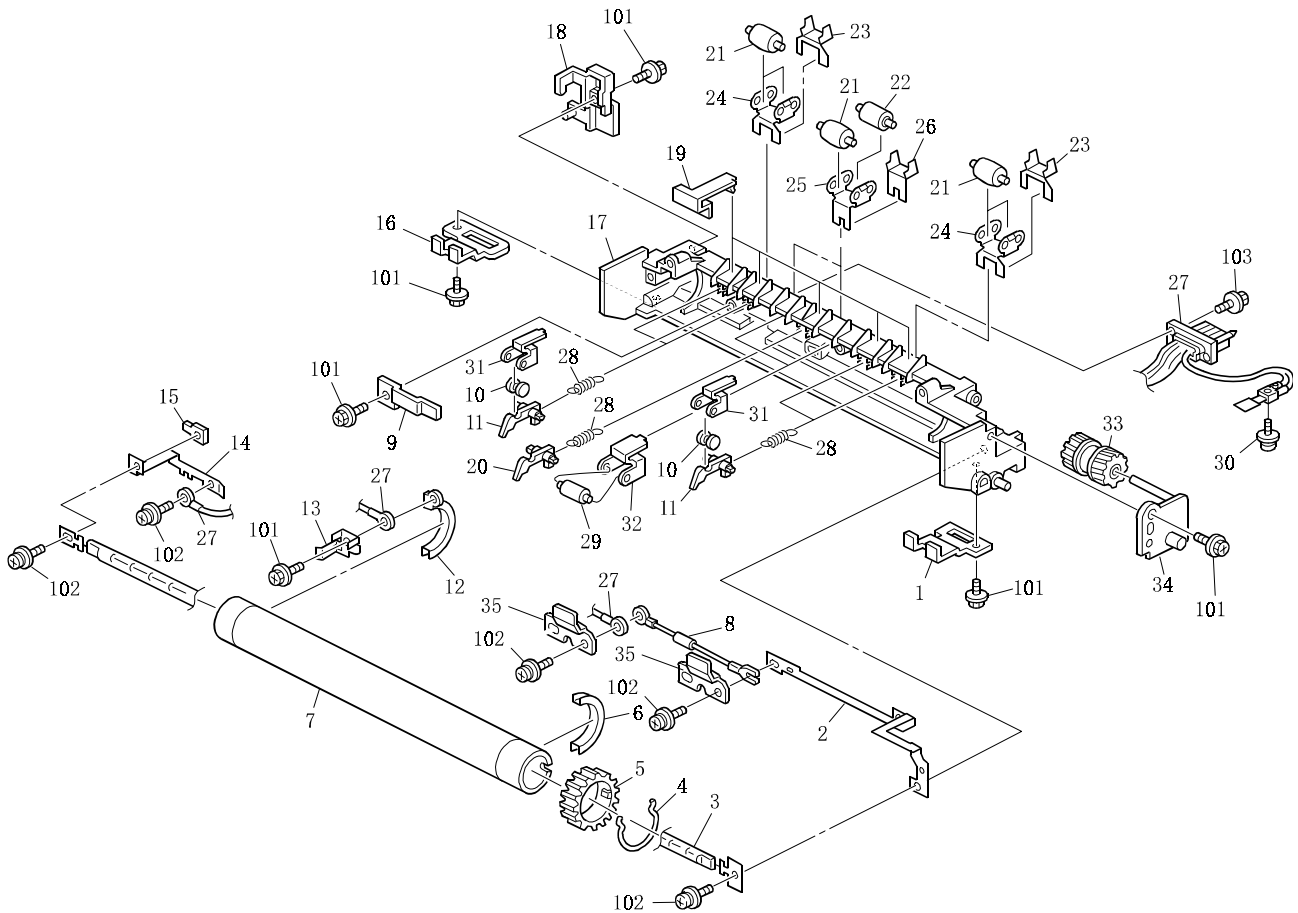

Model: Kaiser1	Date: 08-May-00	No.: MH306004
----------------	-----------------	---------------

For Europe/Asia *1

Old part number	New part number	Description	Q'ty	Int	Page	Index	Note
H3065010	H3065011	PSU	1	X/O	41	26	
H3065207	H3065223	Harness NCU-6P	1	X/O	41	30	
H3065212	H3065224	Harness NCU-4P	1	X/O	41	31	
-	N6074525	Choke Coil RITL-9704	1		41	33	*2

*1: These parts have been used since the first mass production lot.

*2: This part was not included in the original illustration (not a new part).
Please add the index description and illustration.

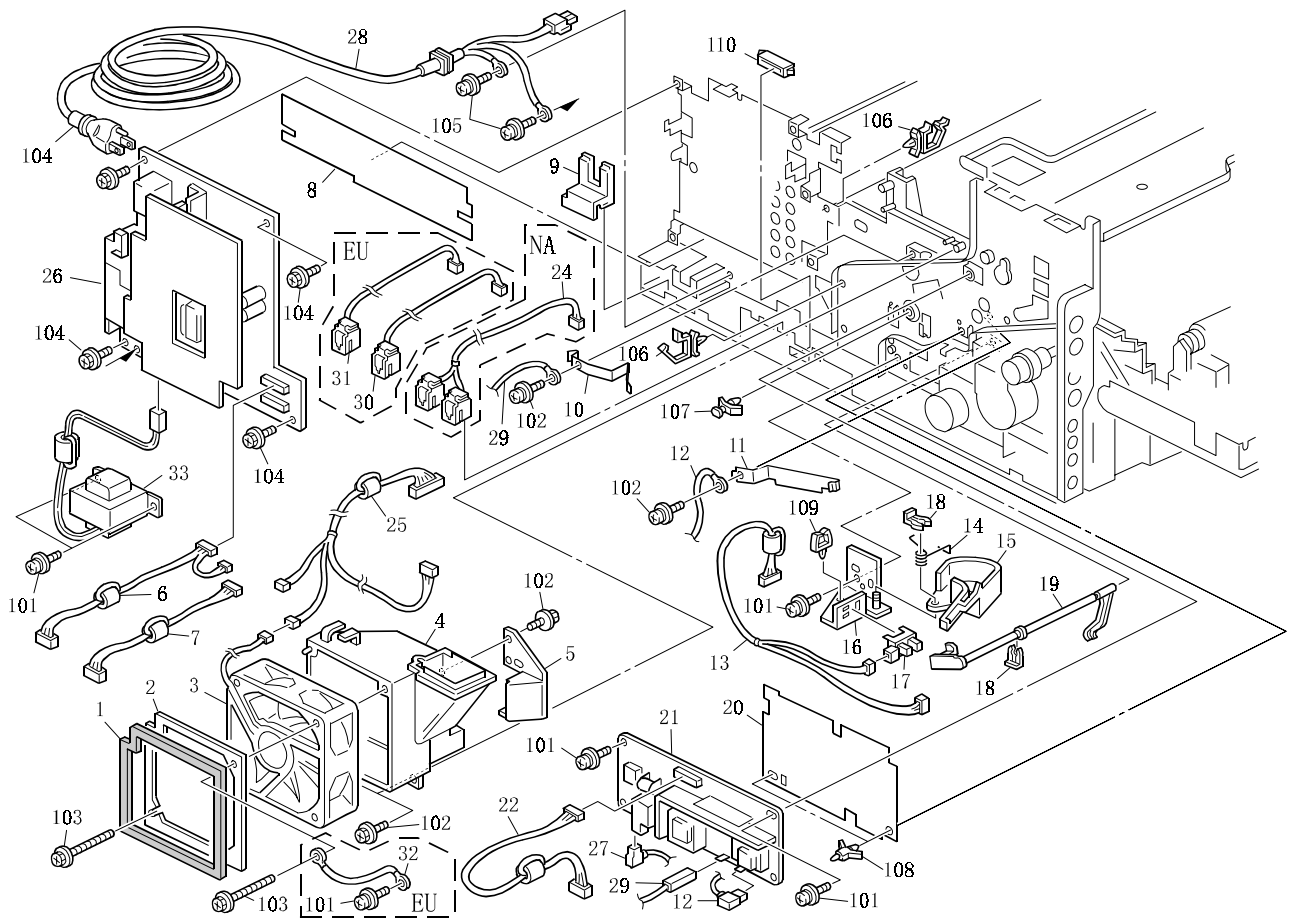

Model: Kaiser1	Date: 08-May-00	No.: MH306004
----------------	-----------------	---------------

For Europe/Asia

Old part number	New part number	Description	Q'ty	Int	Page	Index	Note
-	H3063198	Clamp	1		43	33	*1

*1: This part was not included in the original illustration (not a new part).
Please add the index description and illustration.

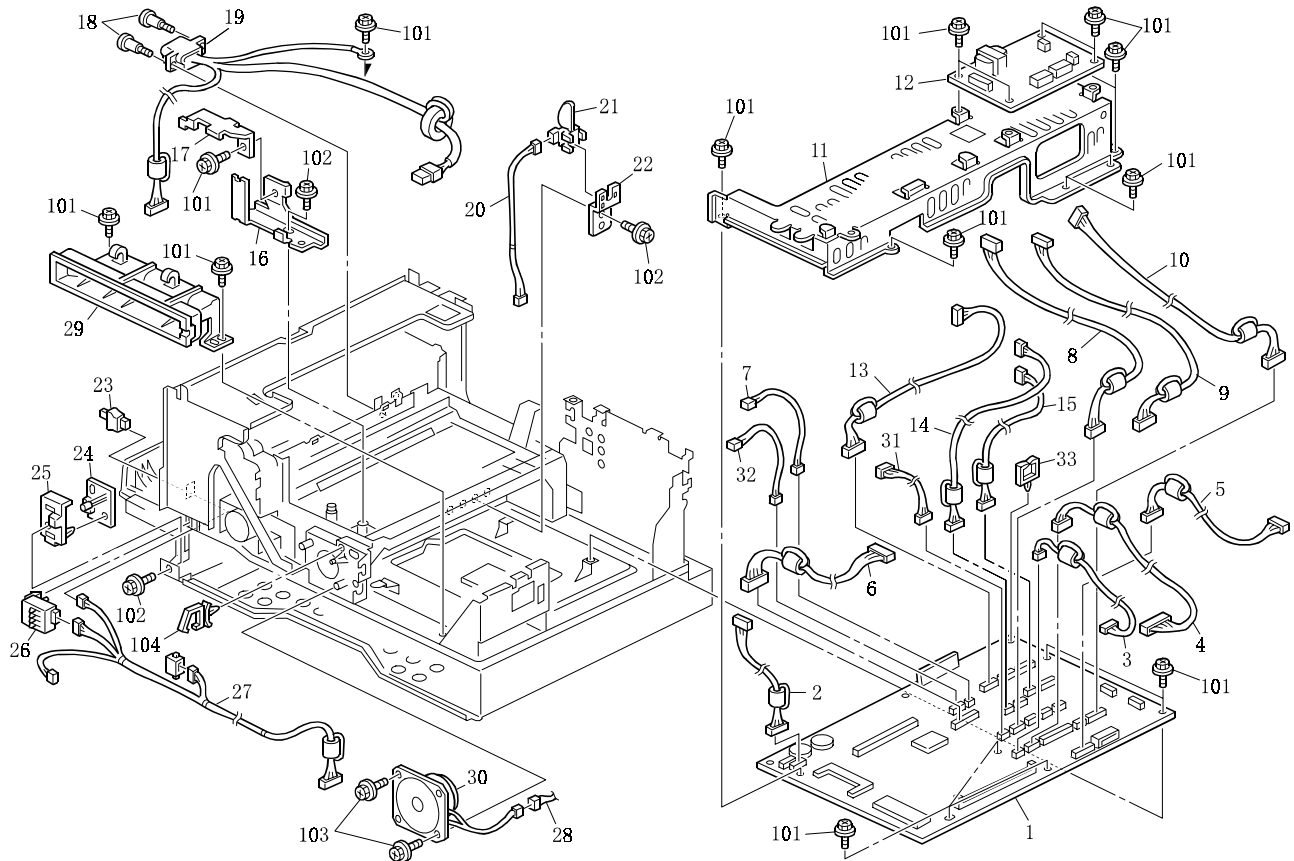

Model: Kaiser1

Date: 08-May-00

No.: MH306004

For Asia

Old part number	New part number	Description	Q'ty	Int	Page	Index	Note
11500024	-	Power Supply Cord	1		41	28	

Power Supply Cord for Asian models has not been contained since May mass production.

SG3 unit for Europe/Asia

Old part number	New part number	Description	Q'ty	Int	Page	Index	Note
H3065207	H3065223	Harness NCU-6P	1	X/O	3	7	

Model: Kaiser1		Date: 05-Jul-00	No.: MH306005
Modified Article: Parts Catalog Corrections		Prepared by: M.Mano	
From: Technical Services Dept., GTS Division			
Reason for Modification:	<input checked="" type="checkbox"/> Parts catalog correction	<input type="checkbox"/> Vendor change	<input type="checkbox"/> To meet standards ()
	<input type="checkbox"/> To facilitate assembly	<input type="checkbox"/> To improve reliability	
	<input type="checkbox"/> Part standardization	<input type="checkbox"/> Other	

Please make the following corrections to your Parts Catalogs.

SG3 (H133)

Old part number	New part number	Description	Q'ty	Int	Page	Index	Note
-	54886141	NCU Board – EU/Asia	1		3	1	*1
-	H3064648	Insulation Sheet	1		3	15	*2
	H3064634	Bracket – NCU	1		3	16	*2

*1: This part number was not included in the original table (not a new part).

*2: These parts were not included in the original illustration (not new parts).

Please add in the three index descriptions above along with the illustration for the Insulation Sheet and the NCU Bracket (#15 and 16, circled below).

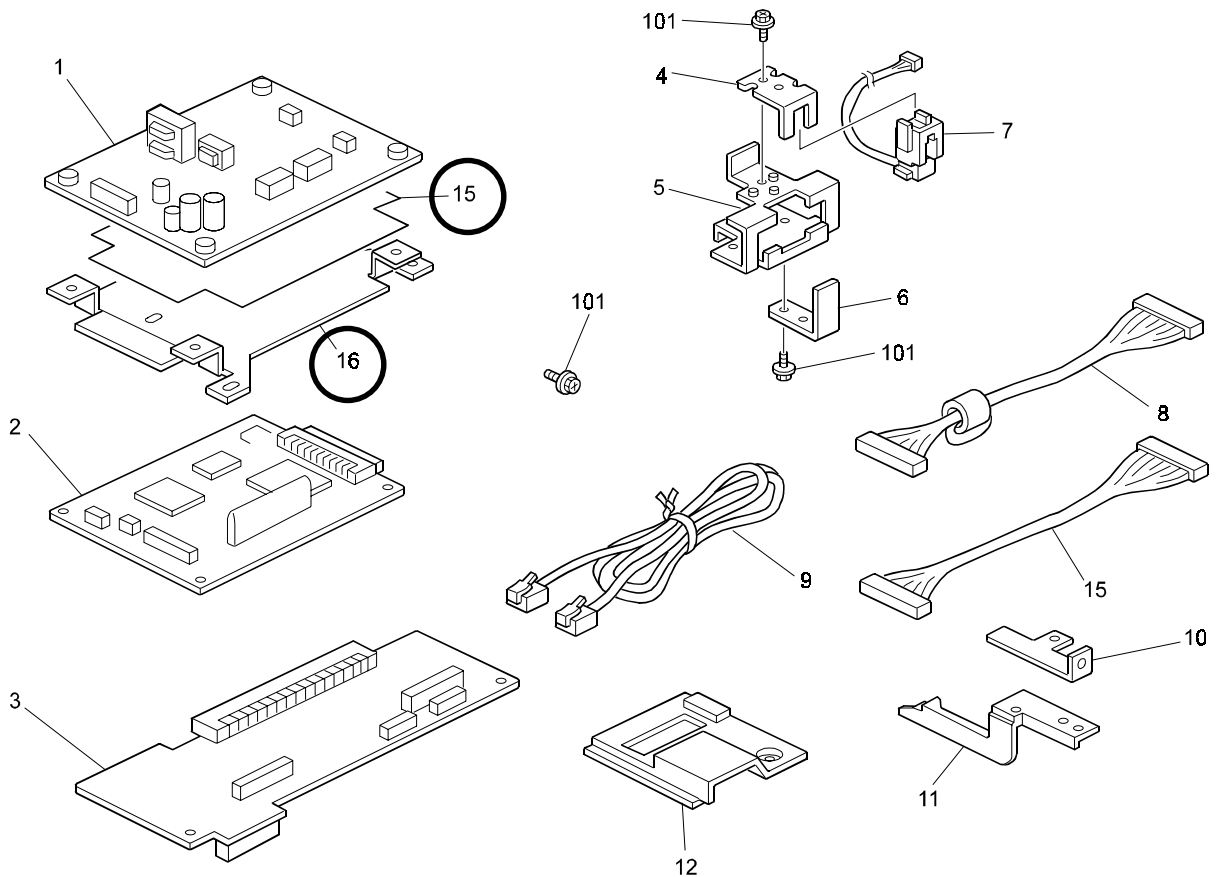

Model: Kaiser1		Date: 25-Aug-00	No.: MH306006
Modified Article: Parts Catalog Corrections		Prepared by: M.Mano	
From: Technical Services Dept., GTS Division			
Reason for Modification:	<input checked="" type="checkbox"/> Parts catalog correction	<input type="checkbox"/> Vendor change	<input type="checkbox"/> To meet standards ()
	<input type="checkbox"/> To facilitate assembly	<input type="checkbox"/> To improve reliability	
	<input type="checkbox"/> Part standardization	<input type="checkbox"/> Other	

Please make the following corrections to your parts catalogs.

For all models: Mainframe (H306)

Old part number	New part number	Description	Q'ty	Int	Page	Index	Note
-	H3061334	Sheet ADF Switch 1	1		13	38	*1
-	H3061335	Sheet ADF Switch 2	1		13	39	*1

*1: This part was not included in the original table or illustration (it is not a new part).

Please add in the two index descriptions above along with the illustration for the Sheet ADF Switch 1 and Sheet ADF Switch 2 (#38 and 39, circled below).

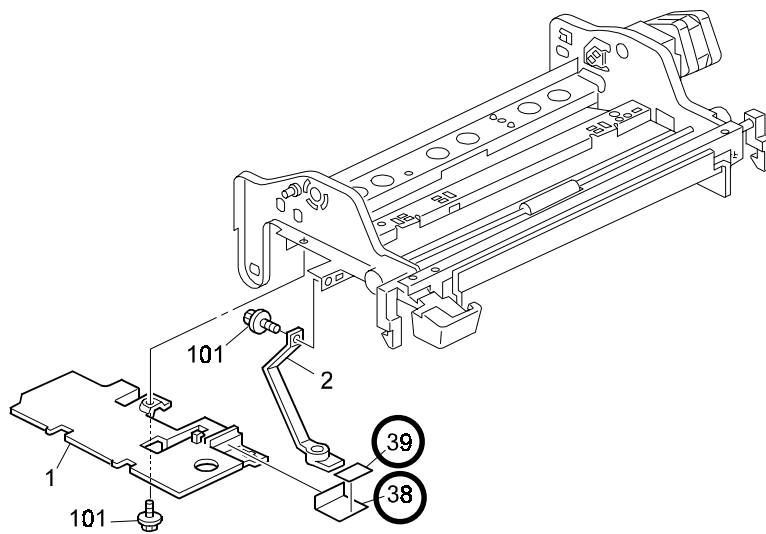

Model: Kaiser1	Date: 25-Aug-00	No.: MH306006
----------------	-----------------	---------------

For all models: Mainframe (H306)

Old part number	New part number	Description	Q'ty	Int	Page	Index	Note
H5235003	AW020075	Photointerrupter	1	X/O	21	5	*1
H3063183	H3062099	Decal – Fusing Cover1	1	O/O	27	7	*2
G0293863	G0293967	Discharge Brush	1	X/O	27	18	*3
H3063129	H3063151	FCU Shield Cover	1	X/O	43	11	*4
G0294175	H3062137	Stripper Pawls	1	O/O	35	20	*2
H3063334	H3063197	Adjusting Screw	1	X/O	45	26	*5
	H3063335	Decal Paper Size	1		29	27	*6

*1: The old part number was misprinted.

*2: The new part will be used after the old part is out of stock.

*3: For the USA, the new part will be used after the old part is out of stock.

For Europe/Asia, the new part will be used from the first mass production lot.

*4: For the USA, the new part has been used since April mass production lot.

For Europe/Asia, the new part will be used from the first mass production lot.

*5: For the USA, the new part has been used since the February mass production lot.

For Europe/Asia, the new part will be used from the first mass production lot.

*6: The new part has been added since the June mass production lot.

(see the following illustration)

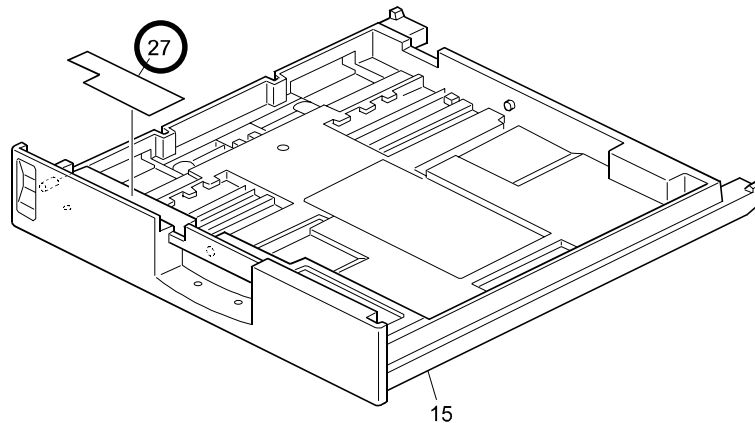

For USA: Mainframe (H306)

Old part number	New part number	Description	Q'ty	Int	Page	Index	Note
H3064067	H3064074	Front Cover	1	X/O	7	20	*1
H3064466	H3064450	LCD Decal	1	X/O	9	2	*1
G0294161	H3065068	Thermofuse - 169°C	1	O/O	35	8	*2

*1: This modification is for the Ricoh model (H306-20) only.

The new part has been used since the June mass production lot.

*2: The new part will be used after the old part is out of stock.

Model: Kaiser1	Date: 25-Aug-00	No.: MH306006
----------------	-----------------	---------------

For Europe/Asia: Mainframe (H306)

Old part number	New part number	Description	Q'ty	Int	Page	Index	Note
H3064053	H3064072	Upper Cover	1	X/O	7	11	*1
H3062166	H3062078	Exit Roller	1	X/O	33	13	*1

*1: The new part will be used from the October mass production lot.

Model: Kaiser1		Date: 25-Aug-00	No.: MH306007
Modified Article: Parts Catalog Correction		Prepared by: M. Mano	
From: Technical Services Dept., GTS Division			
Reason for Modification:	<input checked="" type="checkbox"/> Parts catalog correction	<input type="checkbox"/> Vendor change	<input type="checkbox"/> To meet standards ()
	<input type="checkbox"/> To facilitate assembly	<input type="checkbox"/> To improve reliability	
	<input type="checkbox"/> Part standardization	<input type="checkbox"/> Other	

Please make the following corrections to your parts catalogs.

PIF (H144)

Old part number	New part number	Description	Q'ty	Int	Page	Index	Note
-	H3065148	PIF – FCU Harness NA	1		5	1	*1
H3064640	H3064642	Rear Bracket	1	X/O	5	2	*2

*1: This part number is for the USA model only.

(This part number was not included in the original table: it is not a new part)

*2: This part number was misprinted.

PFU (H110)

Old part number	New part number	Description	Q'ty	Int	Page	Index	Note
H5194547	A8601140	Spring Plate	1	X/O	3	12	*1
-	H5194736	Balancer	2	X/O	5	20	*2
-	H5194725	Paper Feed Shaft	1	X/O	5	22	*2

*1: The new part has been used since the March mass production lot.

*2: This part number is for the Asian model (H110-85) only.

(This part number was not included in the original table: it is not a new part)

Model: Kaiser1		Date: 09-Mar-01	No.: MH306008
Modified Article: Parts Catalog Corrections		Prepared by: M. Mano	
From: Technical Services Dept., GTS Division			
Reason for Modification:	<input checked="" type="checkbox"/> Parts catalog correction	<input type="checkbox"/> Vendor change	<input type="checkbox"/> To meet standards ()
	<input type="checkbox"/> To facilitate assembly	<input type="checkbox"/> To improve reliability	
	<input type="checkbox"/> Part standardization	<input type="checkbox"/> Other	

Please make the following corrections to your Parts Catalogs.

Old part number	New part number	Description	Q'ty	Int	Page	Index	Note
H3061350	H3061410	Stepper Motor Ass'y	1	X/O	17		
H3061373							
H3065060							
H3061351	H3061360	Rear Slow Down Gear	1	X/O	17	22	

* H3061410 contains the stepper motor, the stepper motor cushion and the motor bracket.

In some cases, the stepper motor bracket rattles due to the vibration of the stepper motor, causing a squeaking noise. To ensure this does not occur, the bracket and rear slow down gear have been modified. In addition, the motor, bracket and cushion have been grouped under one part number (H3061410).

Therefore in the field, all four parts (gear and motor assembly) should be replaced together as a set.

The following are the cut-in serial numbers (applied September 2000):
A1400900001~

Model: Kaiser1		Date: 07-Nov-01	No.: MH306009
Modified Article: Kaiser1 Parts Catalog Correction		Prepared by: M. Mano	
From: Technical Services Dept., GTS Division			
Reason for Modification:	<input type="checkbox"/> Parts catalog correction <input type="checkbox"/> To facilitate assembly <input type="checkbox"/> Part standardization	<input type="checkbox"/> Vendor change <input checked="" type="checkbox"/> To improve reliability <input type="checkbox"/> Other	<input type="checkbox"/> To meet standards ()

The following parts have been modified to increase paper feed performance and reliability.

PFU (H110)

Old part number	New part number	Description	Q'ty	Int	Page	Index	Note
H5194717	H3103372	Paper Feed Stay	1	O/O	4	3	
H5194731	H3103368	Paper End Sensor Bracket	1	O/O	4	9	
H5194540	H3103367	Slide Rail	1	O/O	6	5	
H5194756	H3103369	Motor Bracket	1	O/O	6	14	
H5194797	H3103365	Spring Plate	1	O/O	8	5	
H3063501	H3103364	Decal – Size Indication	1	O/O	8	24	
H5194776	H3103373	Paper Tray	1	O/O	8	28	

Model: Kaiser1		Date: 08-Nov-01	No.: MH306010
Modified Article: Kaiser1 Parts Catalog Correction		Prepared by: M.Mano	
From: Technical Services Dept., GTS Division			
Reason for Modification:	<input type="checkbox"/> Parts catalog correction	<input type="checkbox"/> Vendor change	<input type="checkbox"/> To meet standards ()
	<input type="checkbox"/> To facilitate assembly	<input type="checkbox"/> To improve reliability	
	<input type="checkbox"/> Part standardization	<input checked="" type="checkbox"/> Other	

One of the Transport Relay Rollers may shift position along the shaft when clearing a paper feed jam, which can then cause another jam. The roller has been modified to ensure this does not occur.

PFU (H110)

Old part number	New part number	Description	Q'ty	Int	Page	Index	Note
H5194741	H5194742	Transport Relay Roller	1	X/O	6	3	

Model: Kaiser1		Date: 09-Nov-01	No.: MH306011
Modified Article: Kaiser1 Parts Catalog Correction		Prepared by: M.Mano	
From: Technical Services Dept., GTS Division			
Reason for Modification:	<input checked="" type="checkbox"/> Parts catalog correction	<input type="checkbox"/> Vendor change	<input type="checkbox"/> To meet standards ()
	<input type="checkbox"/> To facilitate assembly	<input type="checkbox"/> To improve reliability	
	<input type="checkbox"/> Part standardization	<input type="checkbox"/> Other	

Please add the following to your Parts Catalogs.

NA Model (H306-20)

Old part number	New part number	Description	Q'ty	Int	Page	Index	Note
	H3064447	Keytop – 10key (Asia)	1	---	8	24	

Model: Kaiser1		Date: 12-Nov-01	No.: MH306012
Modified Article: Kaiser1 Parts Catalog Correction		Prepared by: M.Mano	
From: Technical Services Dept., GTS Division			
Reason for Modification:	<input type="checkbox"/> Parts catalog correction <input type="checkbox"/> To facilitate assembly <input type="checkbox"/> Part standardization	<input type="checkbox"/> Vendor change <input checked="" type="checkbox"/> To improve reliability <input type="checkbox"/> Other	<input type="checkbox"/> To meet standards ()

In some cases, the printed text on the number pad keys and Stop key can wear off after extended use. The following have been modified for increased reliability.

NA Model (H306-20)

Old part number	New part number	Description	Q'ty	Int	Page	Index	Note
H3064401	H3064408	Operation Panel Ass'y (NA)	1	X/O	8	1	
H3064448	H3064481	Keytop – 10key (NA)	1	X/O	8	24	
H3064441	H3064479	Keytop – Stop	1	X/O	8	26	

NA OEM Model (H306-29)

Old part number	New part number	Description	Q'ty	Int	Page	Index	Note
H3064402	H3064409	Operation Panel Ass'y (NA)	1	X/O	8	1	
H3064448	H3064481	Keytop – 10key (NA)	1	X/O	8	24	
H3064441	H3064479	Keytop – Stop	1	X/O	8	26	

Europe Model (H306-30/40/60)

Old part number	New part number	Description	Q'ty	Int	Page	Index	Note
H3064403	H3064410	Operation Panel Ass'y (EU)	1	X/O	8	1	
H3064442	H3064478	Keytop – 10key (EU)	1	X/O	8	24	
H3064441	H3064479	Keytop – Stop	1	X/O	8	26	

Asia Model (H306-51/59)

Old part number	New part number	Description	Q'ty	Int	Page	Index	Note
H3064404	H3064411	Operation Panel Ass'y (Asia)	1	X/O	8	1	
H3064447	H3064480	Keytop – 10key (Asia)	1	X/O	8	24	
H3064441	H3064479	Keytop – Stop	1	X/O	8	26	

Model: Kaiser1		Date: 15-Nov-01	No.: MH306013
Modified Article: Kaiser1 Parts Catalog Correction		Prepared by: M.Mano	
From: Technical Services Dept., GTS Division			
Reason for Modification:	<input checked="" type="checkbox"/> Parts catalog correction	<input type="checkbox"/> Vendor change	<input type="checkbox"/> To meet standards ()
	<input type="checkbox"/> To facilitate assembly	<input type="checkbox"/> To improve reliability	
	<input type="checkbox"/> Part standardization	<input type="checkbox"/> Other	

Please add the following to your Parts Catalogs.

OEM Models (H306-23/30)

Old part number	New part number	Description	Q'ty	Int	Page	Index	Note
-----	H3063156	AIO Cap (Lanier, Info)	1	-	44	27	

Model: Kaiser 1		Date: 05-Dec-01	No.: MH306014
Modified Article: Kaiser1 Parts Catalog Correction		Prepared by: M.Mano	
From: Technical Service Dept., GTS Division			
Reason for Modification:	<input type="checkbox"/> Parts catalog correction <input type="checkbox"/> To facilitate assembly <input type="checkbox"/> Part standardization	<input type="checkbox"/> Vendor change <input type="checkbox"/> To improve reliability <input checked="" type="checkbox"/> Other	<input type="checkbox"/> To meet standards ()

To minimize the effect on the environment, the chromium in the following parts has been removed.

NA Models Only (H306-20/23/29)

Old part number	New part number	Description	Q'ty	Int	Page	Index	Note
H3064702	H3064712	Hand Set Bracket 2	1	O/O	6	23	

All Models

Old part number	New part number	Description	Q'ty	Int	Page	Index	Note
H3061099	H3061115	Stopper Bracket	1	O/O	10	1	
H3061258	H3061458	R0 Bracket	1	O/O	12	18	
H3061259	H3061459	R1 Bracket	2	O/O	16	16	
H3061375	H3061475	Tightener Bracket	1	O/O	16	25	
H3061410	H3061510	Stepper Motor Ass'y	1	O/O	16	-	*1
H3063141	H3063241	Lock Lever Stay	1	O/O	26	29	
H3063118	H3063218	Front Support Plate - Short	1	O/O	36	2	
H3063135	H3063235	Drive Shaft Support Plate	1	O/O	36	3	
H3064066	H3064075	Operation Panel Bracket 2	1	O/O	42	17	
H3063157	H3063257	AIO Sensor Bracket	1	O/O	42	22	
H3063175	H3063275	AIO Cap (NA)	1	O/O	44	27	
H3063176	H3063276	AIO Cap (EU)	1	O/O	44	27	
H3063156	H3063256	AIO Cap (Lanier, Info)	1	O/O	44	27	

*1: When replacing the Stepper Motor Assembly, be sure to also replace the Rear Slow Down Gear (H3061360) at the same time. Please see MB #MH306008.

Cut-in Serial Numbers:

Lanier: 1082176 ~

Others: A1410800001~

Model: Kaiser1		Date: 20-Dec-01	No.: MH306015
Modified Article: Parts Catalog Corrections		Prepared by: M. Mano	
From: Technical Service Dept., GTS Division			
Reason for Modification:	<input type="checkbox"/> Parts catalog correction	<input type="checkbox"/> Vendor change	<input type="checkbox"/> To meet standards ()
	<input type="checkbox"/> To facilitate assembly	<input checked="" type="checkbox"/> To improve reliability	
	<input type="checkbox"/> Part standardization	<input type="checkbox"/> Other	

It is possible for the fusing harness cover to become warped due to heat (rare occurrence). To prevent this, its composition has been changed from plastic to metal. Please make the following corrections to your Parts Catalogs.

For all models

Old part number	New part number	Description	Q'ty	Int	Page	Index	Note
G0294138	H3062179	Fusing Harness Cover	1	X/O	34	9	

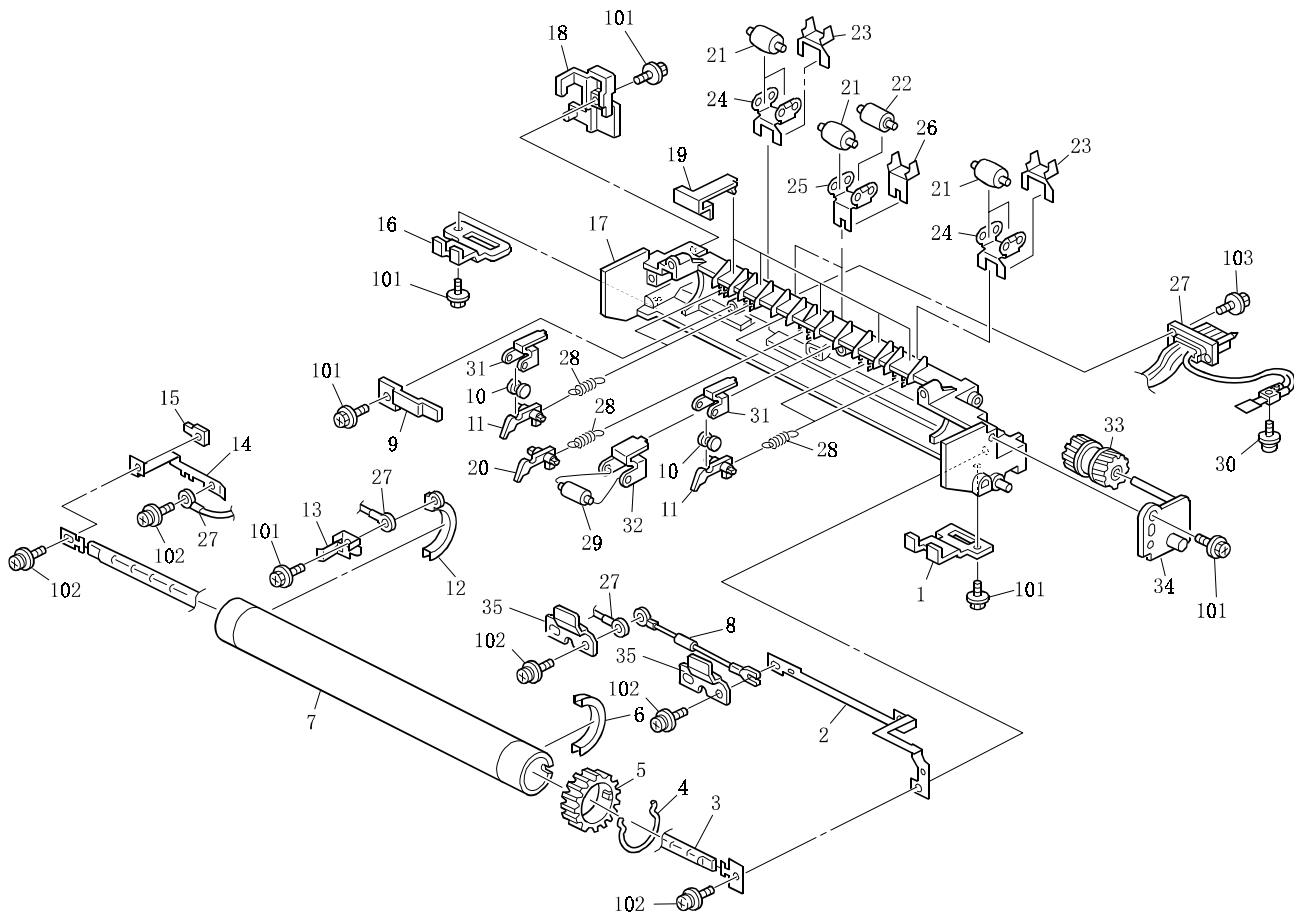

Model: Kaiser1		Date: 4-Mar-02	No.: MH306016
Modified Article: Kaiser1 Parts Catalog Correction		Prepared by: M.Mano	
From: Technical Service Dept., GTS Division			
Reason for Modification:	<input type="checkbox"/> Parts catalog correction	<input type="checkbox"/> Vendor change	<input type="checkbox"/> To meet standards ()
	<input type="checkbox"/> To facilitate assembly	<input type="checkbox"/> To improve reliability	
	<input checked="" type="checkbox"/> Part standardization	<input type="checkbox"/> Other	

The Pickup Roller has been changed due to parts standardization with the new model Kaiser 3 (to be released in the near future).

Note:

1. The color of the new roller is gray (the previous roller was black). Since there is no difference in performance (int. 0/0), both rollers can be used for both models.
2. The new roller will not be used on the Kaiser 1 production line.

Mainframe (H306)

Old part number	New part number	Description	Q'ty	Int	Page	Index	Note
H3061302	H3061292	Pickup Roller	1	O/O	14	20	

Model: Kaiser1		Date: 3-Oct-02	No.: MH306017
Modified Article: Parts Catalog Corrections		Prepared by: M.Mano	
From: Technical Services sec. Service Planning Dept.			
Reason for Modification:	<input checked="" type="checkbox"/> Parts catalog correction	<input type="checkbox"/> Vendor change	<input type="checkbox"/> To meet standards ()
	<input type="checkbox"/> To facilitate assembly	<input type="checkbox"/> To improve reliability	
	<input type="checkbox"/> Part standardization	<input type="checkbox"/> Other	

The following parts have been changed due to parts standardization with the K-3, and are made of a stronger material.

For all models

Old part number	New part number	Description	Q'ty	Int	Page	Index	Note
H3062193	H3102173	Front Release Lever	1	O/O	32	12	
H3062194	H3102174	Rear Release Lever	1	O/O	32	9	

For Europe and Asia models only

Old part number	New part number	Description	Q'ty	Int	Page	Index	Note
H3062078	H3102193	Exit Roller	1	O/O	32	13	

Model: Kaiser 1		Date: 9-Jan-03	No.: MH306018
Modified Article: Parts Catalog Corrections		Prepared by: M. Mano	
From: Technical Services Sec. Service Planning Dept.			
Reason for Modification:	<input checked="" type="checkbox"/> Parts catalog correction	<input type="checkbox"/> Vendor change	<input type="checkbox"/> To meet standards ()
	<input type="checkbox"/> To facilitate assembly	<input type="checkbox"/> To improve reliability	
	<input type="checkbox"/> Part standardization	<input type="checkbox"/> Other	

The following part has been changed due to parts standardization with the K-3

Old part number	New part number	Description	Q'ty	Int	Page	Index	Note
G0291972	H3102701	Shield Glass	1	O/O	45	20	

Model: Kaiser 1		Date: 23-Jan-03	No.: MH306019
Modified Article: Parts Catalog Corrections		Prepared by: M. Mano	
From: Technical Services Sec. Service Planning Dept.			
Reason for Modification:	<input checked="" type="checkbox"/> Parts catalog correction	<input type="checkbox"/> Vendor change	<input type="checkbox"/> To meet standards ()
	<input type="checkbox"/> To facilitate assembly	<input type="checkbox"/> To improve reliability	
	<input type="checkbox"/> Part standardization	<input type="checkbox"/> Other	

The following part has been changed to increase paper feed reliability.

Mainframe (H306)

Old part number	New part number	Description	Q'ty	Int	Page	Index	Note
H5193021	H5193321	Rear Side Fence	1	X/O	29	23	
H5193332	H5193322	Front Side Fence	1	X/O	29	5	

Model: Kaiser 1		Date: 23-Jan-03	No.: MH306020
Modified Article: Parts Catalog Corrections		Prepared by: M. Mano	
From: Technical Services Sec. Service Planning Dept.			
Reason for Modification:	<input checked="" type="checkbox"/> Parts catalog correction	<input type="checkbox"/> Vendor change	<input type="checkbox"/> To meet standards ()
	<input type="checkbox"/> To facilitate assembly	<input type="checkbox"/> To improve reliability	
	<input type="checkbox"/> Part standardization	<input type="checkbox"/> Other	

The following part has been changed to increase paper feed reliability.

PFU (H110)

Old part number	New part number	Description	Q'ty	Int	Page	Index	Note
H5194781	H3103376	Separation Hook - Front	1	X/O	9	11	
H5194782	H3103377	Separation Hook - Rear	1	X/O	9	15	

Model: Kaiser 1		Date: MH306021	No.: MH306021
Modified Article: Parts Catalog Corrections		Prepared by: M. Mano	
From: Technical Services Sec. Service Planning Dept.			
Reason for Modification:	<input checked="" type="checkbox"/> Parts catalog correction	<input type="checkbox"/> Vendor change	<input type="checkbox"/> To meet standards ()
	<input type="checkbox"/> To facilitate assembly	<input type="checkbox"/> To improve reliability	
	<input type="checkbox"/> Part standardization	<input type="checkbox"/> Other	

The following parts have been changed due to parts standardization with the Model K3.

Mainframe (H306)

Old part number	New part number	Description	Q'ty	Int	Page	Index	Note
H3063125	H3103125	Interlock Switch Cover	1	O/O	37	10	
G0291064	H3105072	Toner End Sensor	1	O/O	31	20	

PFU (H110)

Old part number	New part number	Description	Q'ty	Int	Page	Index	Note
AX200129	H3105042	Magnetic Clutch	1	O/O	5	24	
H3103364	-	Decal - Size Indication	1→0	-	9	24	
H5194784	H3103378	Bottom Plate	1	X/O	9	25	

Model: Kaiser 1		Date: 23-Jan-03	No.: MH306022
Modified Article: Parts Catalog Corrections		Prepared by: M. Mano	
From: Technical Services Sec. Service Planning Dept.			
Reason for Modification:	<input checked="" type="checkbox"/> Parts catalog correction	<input type="checkbox"/> Vendor change	<input type="checkbox"/> To meet standards ()
	<input type="checkbox"/> To facilitate assembly	<input type="checkbox"/> To improve reliability	
	<input type="checkbox"/> Part standardization	<input type="checkbox"/> Other	

The material of the following part has been changed to increase paper feed reliability.

Mainframe: Other than Lanier (H306)

Old part number	New part number	Description	Q'ty	Int	Page	Index	Note
H3063361	H3063371	Transport Cover	1	X/O	25	13	

Mainframe: Lanier (H306)

Old part number	New part number	Description	Q'ty	Int	Page	Index	Note
H3063338	H3063372	Transport Cover (Lanier)	1	X/O	25	13	

Model: Kaiser 1		Date: 7-Jan-04	No.: MH306023
Modified Article: Parts Catalog Corrections		Prepared by: T.Shintani	
From: 1st Technical Support Sec. Service Support Dept.			
Reason for Modification:	<input type="checkbox"/> Parts catalog correction <input type="checkbox"/> To facilitate assembly <input type="checkbox"/> Part standardization	<input type="checkbox"/> Vendor change <input checked="" type="checkbox"/> To improve reliability <input type="checkbox"/> Other	<input type="checkbox"/> To meet standards ()

The material of the following part has been changed to improve the endurance of the pressure roller bushing.

<Symptom>

Poor fusing was found in the field as the pressure roller bushing was shaved.
 A chip on the axis of the pressure roller caused the problem.

Old part number	New part number	Description	Q'ty	Int	Page	Index	Note
G0294120	H3062197	Pressure Roller	1	O/O	33	15	